



US009589195B2

(12) **United States Patent**
Aycock et al.

(10) **Patent No.:** **US 9,589,195 B2**
(45) **Date of Patent:** **Mar. 7, 2017**

(54) **POLARIZATION-BASED MAPPING AND PERCEPTION METHOD AND SYSTEM**

(56) **References Cited**

(71) Applicant: **Polaris Sensor Technologies, Inc.**,
Huntsville, AL (US)

U.S. PATENT DOCUMENTS
7,733,464 B2 * 6/2010 David G01S 7/484
356/5.03
8,149,268 B1 * 4/2012 Meyers H04N 5/144
348/42

(72) Inventors: **Todd M. Aycock**, Huntsville, AL (US);
David B. Chenault, Huntsville, AL (US);
Jonathan B. Hanks, Huntsville, AL (US);
John S. Harchanko, Huntsville, AL (US)

(Continued)

FOREIGN PATENT DOCUMENTS

(73) Assignee: **Polaris Sensor Technologies, Inc.**,
Huntsville, AL (US)

WO 01/37000 5/2001

OTHER PUBLICATIONS

(*) Notice: Subject to any disclaimer, the term of this patent is extended or adjusted under 35 U.S.C. 154(b) by 0 days.

International Search Report and Written Opinion issued May 6, 2016 in corresponding International Application No. PCT/US15/47008 filed on Aug. 26, 2015, 14 pages.

(Continued)

(21) Appl. No.: **14/836,549**

(22) Filed: **Aug. 26, 2015**

Primary Examiner — Seyed Azarian

(74) *Attorney, Agent, or Firm* — Angela Holt; Bradley Arrant Boulton Cummings LLP

(65) **Prior Publication Data**

US 2016/0307053 A1 Oct. 20, 2016

Related U.S. Application Data

(63) Continuation-in-part of application No. 14/602,823, filed on Jan. 22, 2015.

(Continued)

(51) **Int. Cl.**
G06K 9/00 (2006.01)
G06T 5/00 (2006.01)

(Continued)

(52) **U.S. Cl.**
CPC **G06K 9/00805** (2013.01); **G06T 5/007** (2013.01); **G08G 9/02** (2013.01);

(Continued)

(58) **Field of Classification Search**
USPC 382/100, 103, 104, 106–107, 154–155, 382/162, 168, 173, 181, 199, 203, 209,

(Continued)

(57) **ABSTRACT**

A method using Long Wave Infrared Imaging Polarimetry for improved mapping and perception of a roadway or path and for perceiving or detecting obstacles comprises recording raw image data using a polarimeter to obtain polarized images of the roadway or area. The images are then corrected for non-uniformity, optical distortion, and registration. IR and polarization data products are computed, and the resultant data products are converted to a multi-dimensional data set for exploitation. Contrast enhancement algorithms are applied to the multi-dimensional imagery to form enhanced object images. The enhanced object images may then be displayed to a user, and/or an annunciator may announce the presence of an object. Further, the vehicle may take evasive action based upon the presence of an object in the roadway.

17 Claims, 7 Drawing Sheets
(5 of 7 Drawing Sheet(s) Filed in Color)

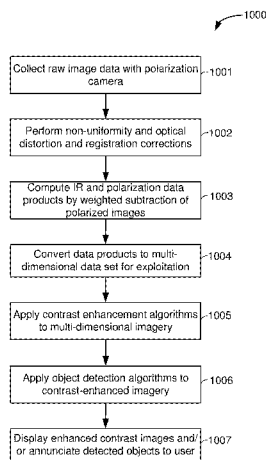

Related U.S. Application Data

(60) Provisional application No. 62/041,778, filed on Aug. 26, 2014, provisional application No. 61/930,272, filed on Jan. 22, 2014.

(51) **Int. Cl.**
G08G 9/02 (2006.01)
H04N 7/18 (2006.01)

(52) **U.S. Cl.**
 CPC *G06T 2207/10048* (2013.01); *G06T 2207/30261* (2013.01)

(58) **Field of Classification Search**
 USPC 382/224, 232, 254, 274, 276, 286–291, 382/305, 312; 348/135, 148, 42; 356/369, 5.03; 250/504
 See application file for complete search history.

(56) **References Cited**

U.S. PATENT DOCUMENTS

8,487,283	B1 *	7/2013	Lee	G01J 3/10 250/504 R
8,755,597	B1 *	6/2014	Tantalo	G06K 9/2018 382/162
8,941,739	B2 *	1/2015	Yoo	G01S 17/88 348/148
2003/0103214	A1	6/2003	VanDelden		
2005/0264813	A1	12/2005	Giakos		
2006/0164643	A1 *	7/2006	Giakos	G01J 3/02 356/369
2008/0035834	A1	2/2008	Gleckler		

2008/0129541	A1	6/2008	Lu et al.		
2009/0147238	A1	6/2009	Markov et al.		
2010/0026555	A1	2/2010	Whittaker et al.		
2010/0271475	A1	10/2010	Schwiegerling et al.		
2012/0075473	A1	3/2012	Sarwar et al.		
2012/0105639	A1	5/2012	Stein et al.		
2012/0170116	A1	7/2012	Gurton		
2013/0027557	A1	1/2013	Hirai et al.		
2013/0293871	A1	11/2013	Gruev		
2014/0078298	A1 *	3/2014	Kudenov	G01J 3/2803 348/135
2014/0184800	A1	7/2014	Hirai et al.		
2014/0244153	A1	8/2014	Dorum et al.		
2015/0023553	A1	1/2015	Rosario et al.		
2015/0219437	A1	8/2015	Dowski et al.		

OTHER PUBLICATIONS

J. Scott Tyo et al., "Review of passive imaging polarimetry for remote sensing applications," *Applied Optics*, vol. 45, No. 22, Aug. 1, 2006, pp. 5453-5469.

W. D. Ross et al., "Multi-Sensor 3D Image Fusion and Interactive Search," Massachusetts Institute of Technology, Jul. 13, 2000, 8 pages.

C. N. Dickson et al., "Improving infrared vehicle detection with polarisation," Herio Watt University, Edinburgh, UK, Dec. 2013, 7 pages.

J. Scott Tyo et al., "The effects of thermal equilibrium and contrast in LWIR polarimetric images," *Optics Express*, vol. 15, No. 23, Nov. 12, 2007 (published Oct. 31, 2007), pp. 15161-15167.

International Search Report and Written Opinion issued Nov. 2, 2015 in related International Application No. PCT/US15/12446 filed on Jan. 22, 2015, 10 pages.

* cited by examiner

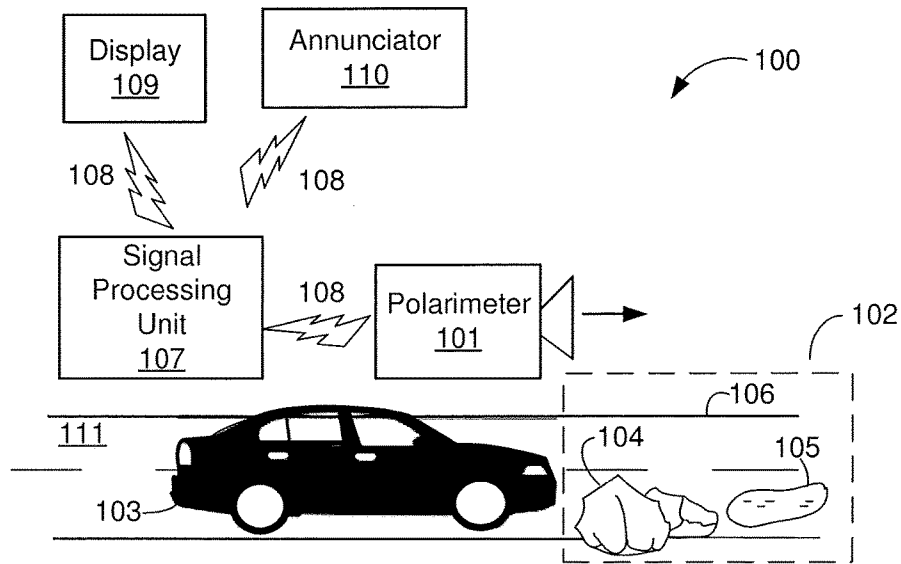

FIG. 1

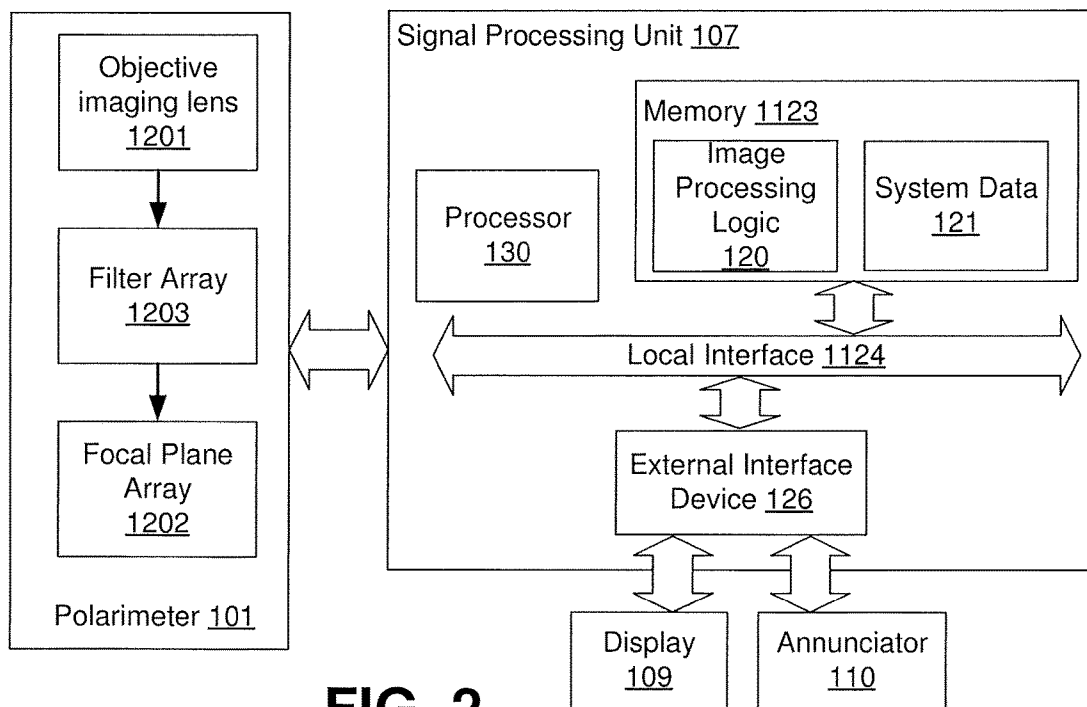

FIG. 2

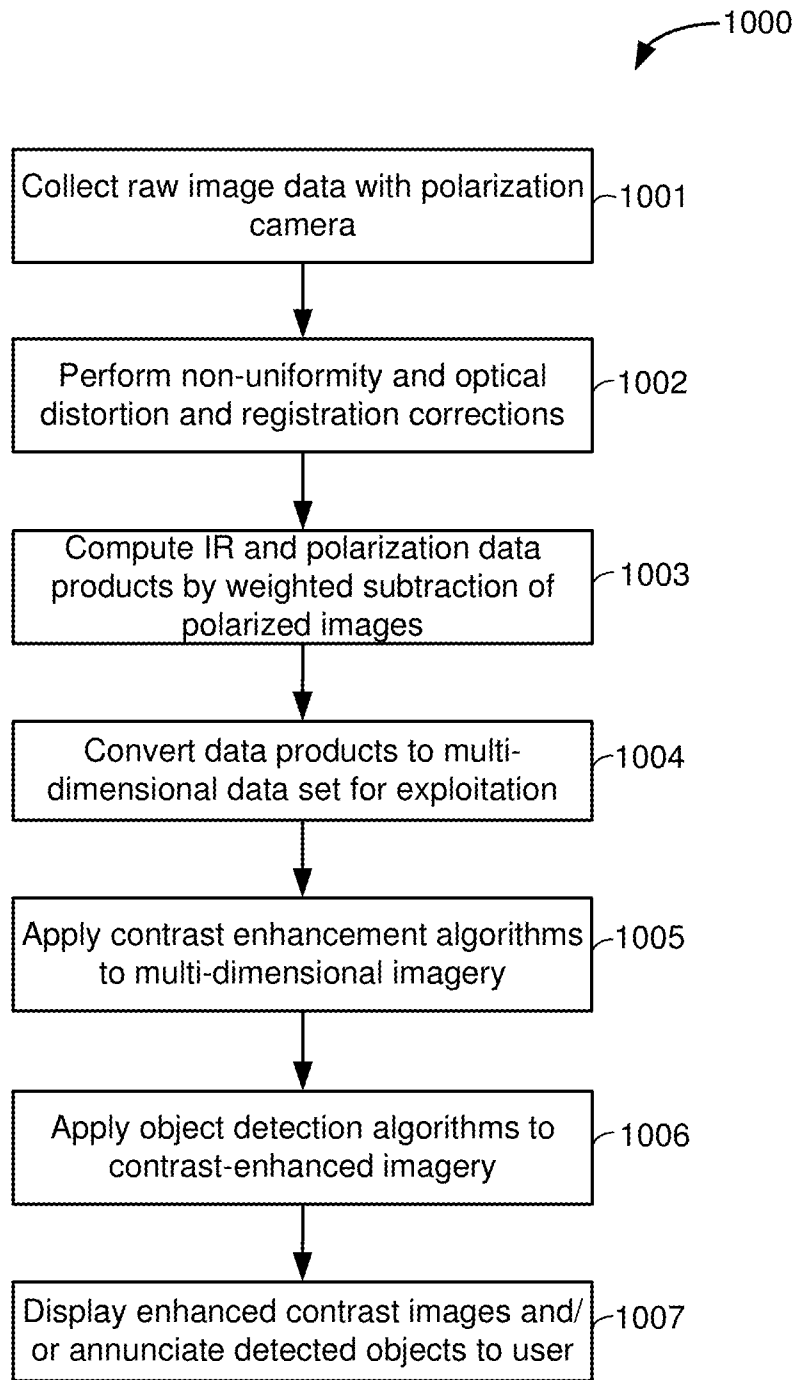

FIG. 3

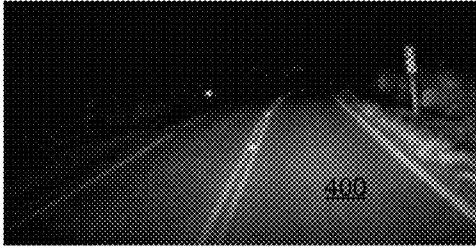

Fig. 4a

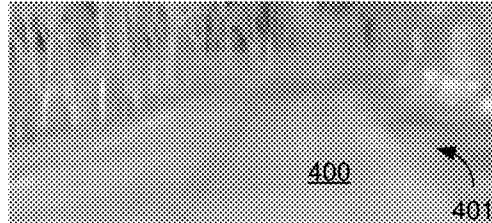

Fig. 4b

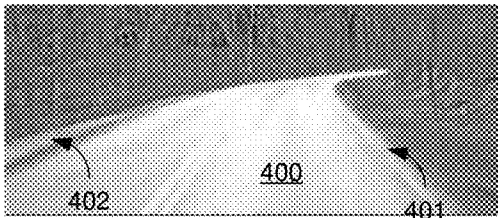

Fig. 4c



Fig. 5a

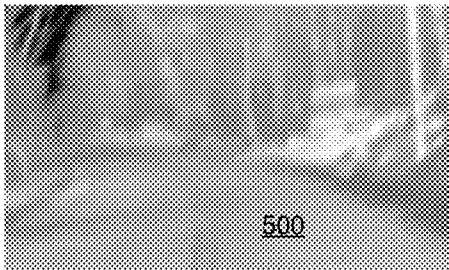

Fig. 5b

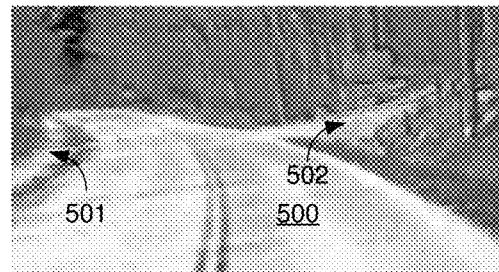

Fig. 5c

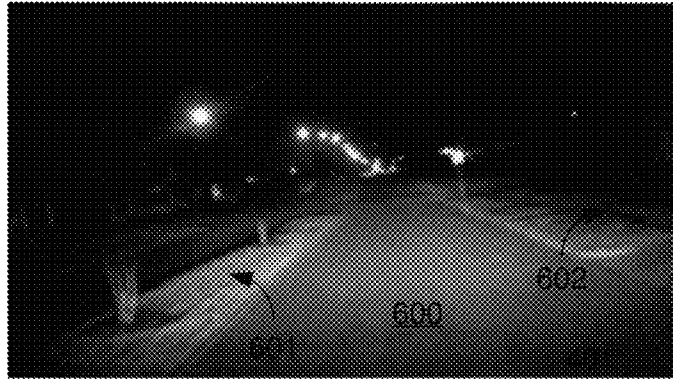

Fig. 6a

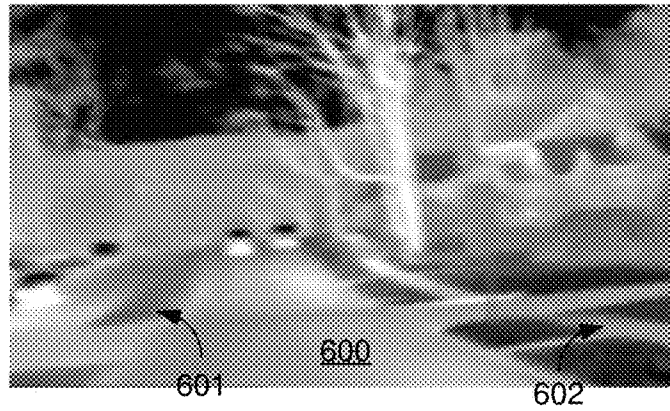

Fig. 6b

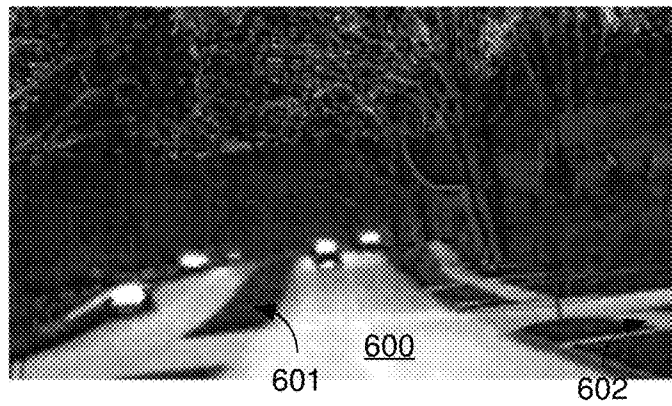

Fig. 6c

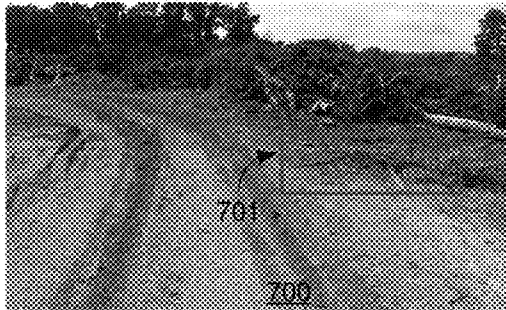

Fig. 7a

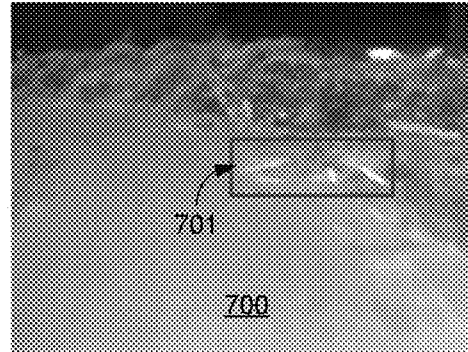

Fig. 7b

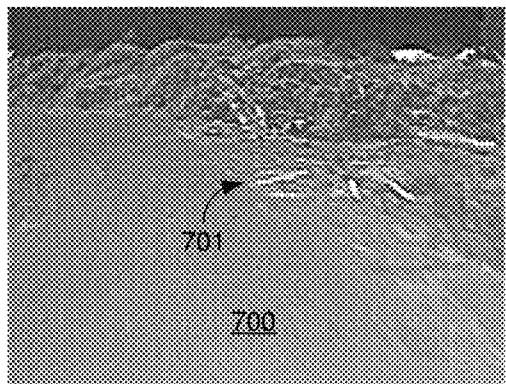

Fig. 7c

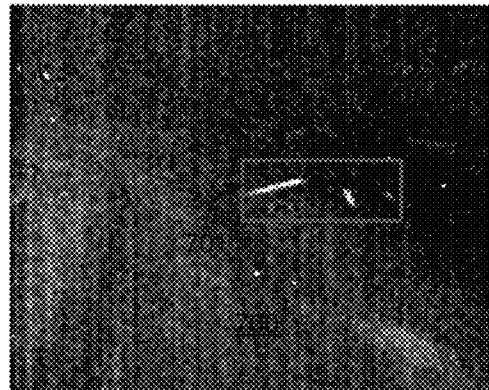

Fig. 7d

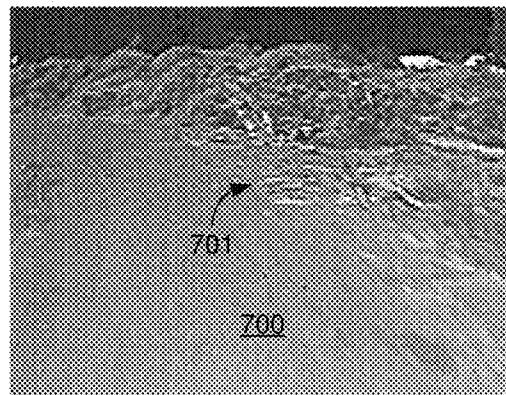

Fig. 7e

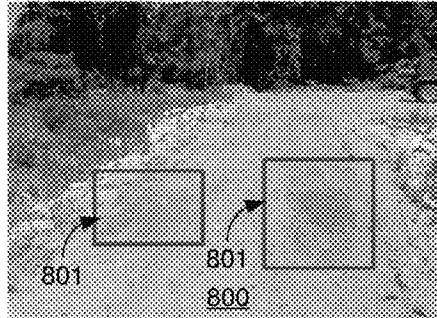

Fig. 8a

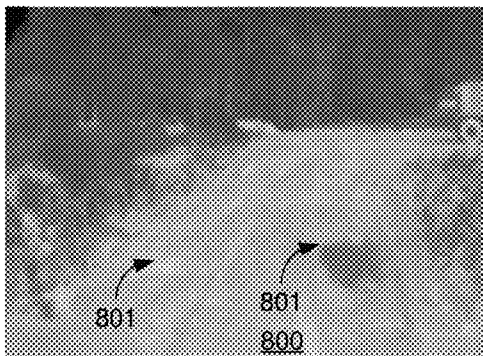

Fig. 8b

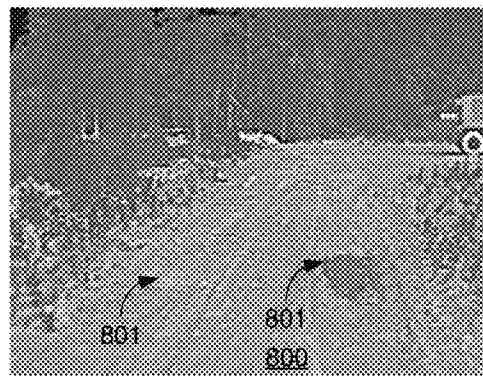

Fig. 8c

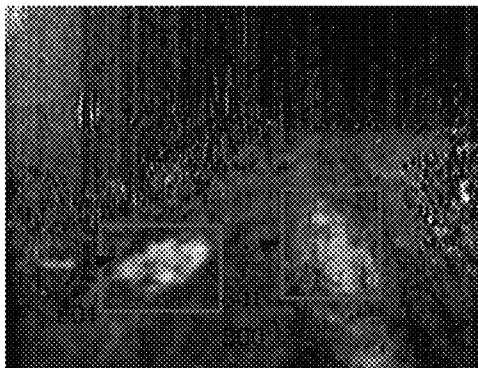

Fig. 8d

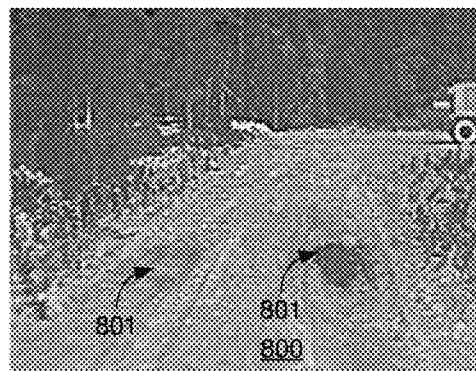

Fig. 8e

Fig. 9a

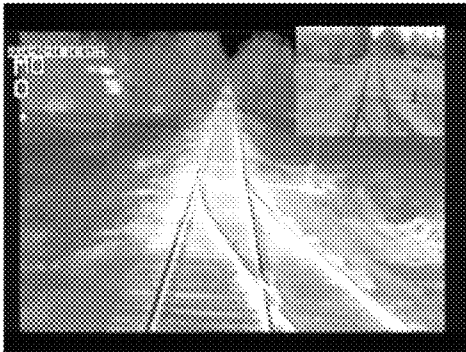

Fig. 9a

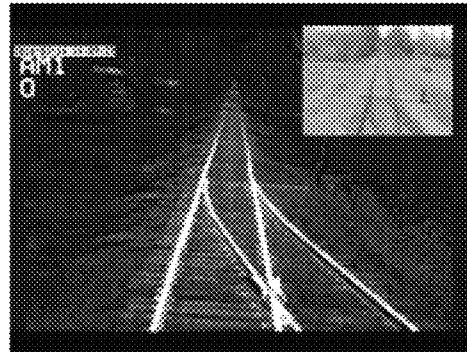

Fig. 9b

Fig. 9c

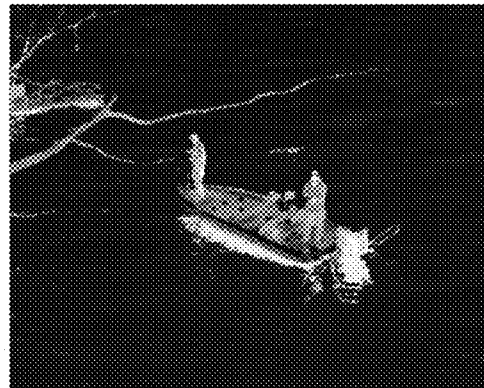

Fig. 10a

Fig. 10b

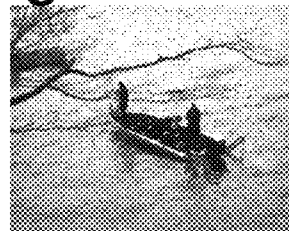

Fig. 10c

Fig. 10d

Fig. 10e

POLARIZATION-BASED MAPPING AND PERCEPTION METHOD AND SYSTEM

REFERENCE TO RELATED APPLICATIONS

This application claims the benefit of and priority to Provisional Patent Application U.S. Ser. No. 62/041,778, entitled "Polarization-based Mapping and Perception System and Method," and filed on Aug. 26, 2014, which is fully incorporated herein by reference. This application further is a continuation-in-part of U.S. Non-Provisional application Ser. No. 14/602,823, entitled "Polarization Imaging for Facial Recognition Enhancement System and Method," and filed on Jan. 22, 2015, which claims the benefit of U.S. Provisional Application No. 61/930,272, entitled "Polarization Imaging for Facial Recognition Enhancement," and filed on Jan. 22, 2014, both of which are fully incorporated herein by reference.

GOVERNMENT LICENSE RIGHTS

This invention was made with government support under Contract Number N00014-13-C-0290 awarded by the U.S. Navy. The government has certain rights in the invention.

BACKGROUND AND SUMMARY

As used herein, Long Wave Infrared is referred to as "LWIR" or "thermal." As used herein, "mapping" refers to placing objects in a scene relative to other objects or elements in the scene. As an example, "that little rock is in the road next to that big rock just off the road." As used herein, "roadway" refers to any path along which a person, animal, or vehicle may traverse.

A method using Long Wave Infrared Imaging Polarimetry for improved mapping and perception of a roadway or path and for perceiving or detecting objects is disclosed herein. The described method is not tied to any one specific polarimeter sensor architecture, and thus the method described pertains to all LWIR sensors capable of detecting the critical polarimetric signature. The method comprises recording raw image data of an area using a polarimeter to obtain polarized images of the area. The images are then corrected for non-uniformity, optical distortion, and registration in accordance with the procedure necessitated by the sensor's architecture. IR and polarization data products are computed, and the resultant data products are converted to a multi-dimensional data set for exploitation. Contrast enhancement algorithms are applied to the multi-dimensional imagery to form enhanced object images. The enhanced object images may then be displayed to a user, and/or an annunciator may announce the presence of an object. Further, the vehicle may take evasive action based upon the presence of an object in the roadway.

A standard IR camera gives information about an IR signature (i.e., how bright a target looks), spatial information (i.e., where a target is in the scene), and temporal information (i.e., how the target changes in the scene from frame to frame). A polarimetric system and method as disclosed herein provides all of this information and also a polarimetric signature.

DESCRIPTION OF THE DRAWINGS

The patent or application file contains at least one drawing executed in color. Copies of this patent or patent application

publication with color drawings will be provided by the Office upon request and payment of the necessary fee.

FIG. 1 is a block diagram illustrating a system in accordance with an exemplary embodiment of the present disclosure.

FIG. 2 depicts an exemplary polarimeter and signal processing unit as depicted in FIG. 1.

FIG. 3 is a flowchart depicting exemplary architecture and functionality of the system logic in accordance with an exemplary embodiment of the disclosure.

FIG. 4a depicts a visible image of a roadway at night.

FIG. 4b is a thermal image of the same roadway at night.

FIG. 4c depicts a polarization image of the roadway obtained with the system and method according to an exemplary embodiment of the present disclosure.

FIG. 5a is a visible image of a roadway during the daytime.

FIG. 5b is a thermal image of the roadway of FIG. 5a.

FIG. 5c is a polarization image of the roadway of FIG. 5a obtained with the system and method according to an exemplary embodiment of the present disclosure.

FIG. 6a is a visible image of a roadway that has a median and sidewalk, shown at night.

FIG. 6b is a thermal image of the roadway of FIG. 6a, also at night.

FIG. 6c is a polarization image of the roadway of FIG. 6a obtained with the system and method according to an exemplary embodiment of the present disclosure.

FIG. 7a is a visible image of a dirt road depicting exemplary obstacles on the road.

FIG. 7b is a thermal image of the road of FIG. 7a.

FIG. 7c is a contrast enhanced thermal image of the road of FIG. 7a.

FIG. 7d is a polarization image of the road of FIG. 7a.

FIG. 7e is a ColorFuse image of the road of FIG. 7d.

FIG. 8a is a visible image of a dirt road depicting exemplary obstacles the road at night.

FIG. 8b is a thermal image of the road FIG. 8a.

FIG. 8c is a contrast enhanced thermal image of the road of FIG. 8a.

FIG. 8d is a polarization image of the road of FIG. 8a.

FIG. 8e is a ColorFuse image of the roadway of FIG. 8d.

FIG. 9a depicts a visible image of train tracks.

FIG. 9b is a thermal image of the train tracks of FIG. 9a.

FIG. 9c is a polarization image of the train tracks of FIG. 9a.

FIG. 10a is a Stokes vector image S_0 of a maritime scene showing fishermen in a boat.

FIG. 10b is a ColorFuse image of the scene of FIG. 10a.

FIG. 10c is a Stokes vector images S_1 of the maritime of FIG. 10a.

FIG. 10d is a Stokes vector images S_2 of the maritime of FIG. 10a.

FIG. 10e is a DoLP image of the maritime scene of FIG. 10a.

DETAILED DESCRIPTION

FIG. 1 illustrates a system 100 in accordance with an exemplary embodiment of the present disclosure. The system 100 comprises a polarimeter 101 mounted on a vehicle 103 and a signal processing unit 107, which collect and analyze images of a surface 111 for detection and announcement of an object 102. Exemplary objects 102 shown in FIG. 1 include an obstacle 104, water or mud puddle 105, and a roadway edge 106. As used in this disclosure, the term "object" may refer to any object, pathway defect or area of

interest, including in some embodiments humans or other animals. In FIG. 1, the obstacle **104** and the puddle **105** are objects the vehicle would want to avoid. The roadway edge **106** is an object that the vehicle would want to know the location of, in order to stay on a roadway. Thus in some embodiments, the objects **102** are objects to be avoided or located in order to safely navigate the vehicle **103**. In other embodiments, the objects **102** are items in need of location, for example, humans during search and rescue operations, as further discussed herein.

The polarimeter **101** comprises a polarizing imaging device for recording polarized images, such as a digital camera or thermal imager that collects images. The vehicle **103** may be an automobile, watercraft, aircraft, or any navigable vehicle, or a human on foot. The polarimeter **101** collects raw image data of the roadway environment consisting of the surface **111** (a roadway, for example), and objects **102** such as the obstacle **104**, the water or mud puddle **105**, and the roadway edge **106**.

The polarimeter **101** transmits raw image data to the signal processing unit **107**, which processes the data as further discussed herein. The processed data is then displayed to the operator on display **108** or detection is annunciated on an annunciator **110**, as further discussed herein. Although FIG. 1 shows the polarimeter **101**, the signal processing unit **107**, the display **109**, and annunciator **110** as separate items, the polarimeter **101** and signal processing unit **107** are packaged into one device in certain embodiments and placed on the vehicle **103** such that the polarimeter has a view of the roadway, and with the display **109** and annunciator **110** packaged together and placed inside the vehicle.

In the illustrated embodiment, the polarimeter **101** sends raw image data (not shown) to the signal processing unit **107** over a network or communication channel **108** and processed data sent to the display **109** and annunciator **110**. The signal processing unit **107** may be any suitable computer known in the art or future-developed. The signal processing unit **107** receives the raw image data, filters the data, and analyzes the data as discussed further herein to provide enhanced imagery and detections and annunciations. The network **108** may be of any type network or networks known in the art or future-developed, such as a simple communications cable, the internet backbone, Ethernet, Wifi, WiMax, broadband over power line, coaxial cable, and the like. The network **108** may be any combination of hardware, software, or both. Further, the network **108** could be resident in a sensor (not shown) housing both the polarimeter **101** and the signal processing unit **107**.

In another exemplary embodiment (not shown), the vehicle **103** comprises manned or unmanned (autonomous) agricultural equipment in a farming environment and the objects **102** include obstacles along farm roads or in fields. In another embodiment, the vehicle **103** comprises manned or unmanned (autonomous) vessels that operate on waterways or oceans and the objects **102** are floating in the water. In another exemplary embodiment (not shown), the vehicle **103** comprises a person or vessel conducting search and rescue activities and objects **102** are victims of an incident involving bodies of water. In another exemplary embodiment (not shown), the vehicle **103** comprises manned or unmanned (autonomous) aircraft and objects **102** are those found in an airfield environment, including runways and the grassy areas in and around runways. In another exemplary embodiment (not shown), the vehicle **103** comprises railroad equipment and the objects **102** are those found in the environment around railroad tracks and switches.

FIG. 2 depicts an exemplary polarimeter **101** and signal processing unit **107** according to an embodiment of the present disclosure. The polarimeter **101** comprises an objective imaging lens **1201**, a filter array **1203**, and a focal plane array **1202**. The objective imaging lens **1201** comprises a lens pointed at the surface **111** (FIG. 1). The filter array **1203** filters the images received from the objective imaging lens system **1201**. The focal plane array **1202** comprises an array of light sensing pixels.

The signal processing unit **107** comprises image processing logic **120** and system data **121**. In the exemplary signal processing unit **107** image processing logic **120** and system data **121** are shown as stored in memory **1123**. The image processing logic **120** and system data **121** may be implemented in hardware, software, or a combination of hardware and software.

The signal processing unit **107** also comprises a processor **130**, which comprises a digital processor or other type of circuitry configured to run the image processing logic **120** by processing the image processing logic **120**, as applicable. The processor **130** communicates to and drives the other elements within the signal processing unit **107** via a local interface **1124**, which can include one or more buses. When stored in memory **1123**, the image processing logic **120** and the system data **121** can be stored and transported on any computer-readable medium for use by or in connection with logic circuitry, a processor, an instruction execution system, apparatus, or device, such as a computer-based system, processor-containing system, or other system that can fetch the instructions from the instruction execution system, apparatus, or device and execute the instructions. In the context of this document, a “computer-readable medium” can be any means that can contain, store, communicate, propagate, or transport the program for use by or in connection with the instruction execution system, apparatus, or device. The computer readable medium can be, for example but not limited to, an electronic, magnetic, optical, electromagnetic, infrared, or semiconductor system, apparatus, device, or propagation medium.

Exemplary system data **121** is depicted comprises:

- a. Raw image data (not pictured) from the polarimeter **101** (FIG. 2) obtained from step **1001** of the method **100** (FIG. 3).
- b. Corrected image data (not pictured), which is the data that has been corrected for non-uniformity, optical distortion, and registration per step **1002** of the method **1000** (FIG. 3).
- c. Thermal (IR) and Polarization images obtained from step **1003** of the method **1000** (FIG. 3).
- d. Conversion of polarization and thermal data to multi-dimensional image data applied in step **1004** of the method **1000** (FIG. 3).
- e. Contrast enhancing algorithms applied to image data in step **1005** of the method **1000** (FIG. 3).
- f. Object detection algorithms applied to contrast enhanced image data in step **1006** of the method **1000** (FIG. 3).
- g. Image data applied to the display **109** and annunciator **110** in step **1007** of the method **1000** (FIG. 3).
- h. Thermal image data as described herein.
- i. Hybrid thermal/polarization images as described herein.

The image processing logic **120** executes the processes described herein with respect to FIG. 3.

Referring to FIG. 2, an external interface device **126** connects to and communicates with the display **109** and annunciator **110**. The external interface device **126** may also communicate with or comprise an input device, for example,

a keyboard, a switch, a mouse, a touchscreen, and/or other type of interface, which can be used to input data from a user of the system 100. The external interface device 126 may also or alternatively communicate with or comprise a personal digital assistant (PDA), computer tablet device, laptop, portable or non-portable computer, cellular or mobile phone, or the like. The external interface device 126 may also or alternatively communicate with or comprise a non-personal computer, e.g., a server, embedded computer, field programmable gate array (FPGA), microprocessor, or the like.

The external interface device 126 is shown as part of the signal processing unit 107 in the exemplary embodiment of FIG. 2. In other embodiments, the external interface device 126 may be outside of the signal processing unit 107.

The display device 109 may consist of a tv, lcd screen, monitor or any electronic device that conveys image data resulting from the method 1000 or is attached to a personal digital assistant (PDA), computer tablet device, laptop, portable or non-portable computer, cellular or mobile phone, or the like. The annunciator device 110 can consist of a warning buzzer, bell, flashing light, or any other auditory or visual or tactile means to warn the operator of the detection of an object or obstacle.

In some embodiments, autonomous action may be taken based upon the objects 102 (FIG. 1) detected. For example, the vehicle 103 (FIG. 1) may automatically be directed to avoid objects 102. In this regard, the external interface device 126 may interface with the vehicle 103 such that the processor 130 may direct the vehicle to swerve around an object 102. In some cases where automatic action is taken, the annunciator 110 may not be required.

In other embodiments, a Global Positioning System ("GPS") device (not shown) may interface with the external interface device 126 to provide a position of the objects 102 detected.

In the illustrated embodiment, the display 109 and annunciator 110 are shown as separate, but the annunciator 110 may be combined with the display 109, and in another embodiments, annunciation could take the form of highlighted boxes or regions or another means used to highlight the object as part of the image data display. For example, an indicator box (e.g., a red box (not shown)), can provides a visual indication of an object 102 detected.

FIG. 3 is a flowchart depicting exemplary architecture and functionality of the image processing logic 120 (FIG. 2) in accordance with a method 1000. In step 1001 of the method 1000, the polarimeter 101 captures an image of a roadway scene from a vehicle on a roadway 111 (FIG. 1) and sends raw image data to the signal processing unit 107 (FIG. 1).

In step 1002, the signal processing unit 107 (FIG. 1) corrects imager non-uniformity of the images received from the polarimeter 101. Examples of imager non-uniformity include fixed pattern lines in the image, noisy pixels, bad pixels, bright spots, and the like. Algorithms that are known in the art may be used for correcting the imager non-uniformity. In some embodiments, step 1002 is not performed because the imager non-uniformity does not require correction.

Additionally in step 1002, the signal processing unit 107 removes image distortion from the image data. An example of image distortion is warping at the edges of the image caused by the objective imaging lens system. Algorithms that are known in the art may be used for correcting image distortion. Registration corrections may also be performed in step 1002, using methods known in the art.

In step 1003, IR and polarization data products are computed. In this step, Stokes parameters (S_0, S_1, S_2) are

calculated by weighted subtraction of the polarized image obtained in step 1002. The LWIR imaging polarimeter measures both a radiance image and a polarization image. A radiance image is a standard image whereby each pixel in the image is a measure of the radiance, typically expressed in Watts/cm²-sr, reflected or emitted from that corresponding pixel area of the scene. Standard photographs and thermal images are radiance images, simply mappings of the radiance distribution emitted or reflected from the scene. A polarization image is a mapping of the polarization state distribution across the image. The polarization state distribution is typically expressed in terms of a Stokes image.

Of the Stokes parameters, S_0 represents the conventional LWIR thermal image with no polarization information. S_1 and S_2 display orthogonal polarimetric information. Thus the Stokes vector, first introduced by G. G. Stokes in 1852, is useful for describing partially polarized light and is defined as

$$\vec{S} = \begin{bmatrix} S_0 \\ S_1 \\ S_2 \\ S_3 \end{bmatrix} = \begin{bmatrix} I_0 + I_{90} \\ I_0 - I_{90} \\ I_{45} - I_{135} \\ I_R - I_L \end{bmatrix} \quad (1)$$

Where I_0 is the radiance that is linearly polarized in a direction making an angle of 0 degrees with the horizontal plane, I_{90} is radiance linearly polarized in a direction making an angle of 90 degrees with the horizontal plane. Similarly I_{45} and I_{135} are radiance values of linearly polarized light making an angle of 45° and 135° with respect to the horizontal plane. Finally I_R and I_L are radiance values for right and left circularly polarized light. For this invention, right and left circularly polarized light is not necessary and the imaging polarimeter does not need to measure these states of polarization. For this reason, the Stokes vectors that we consider will be limited to the first 3 elements which express linearly polarized light only,

$$\vec{S} = \begin{bmatrix} S_0 \\ S_1 \\ S_2 \end{bmatrix} = \begin{bmatrix} I_0 + I_{90} \\ I_0 - I_{90} \\ I_{45} - I_{135} \end{bmatrix} \quad (2)$$

Another useful form of equation (2) is a normalized form of the equation given by

$$\vec{s} = s_0 \begin{bmatrix} 1 \\ s_1/s_0 \\ s_2/s_0 \end{bmatrix} = (I_0 + I_{90}) \begin{bmatrix} 1 \\ (I_0 - I_{90})/(I_0 + I_{90}) \\ (I_{45} - I_{135})/(I_0 + I_{90}) \end{bmatrix} \quad (3)$$

The polarization state emitted or reflected from the roadway surface, surfaces to the side of the road, and objects or surfaces in the road depends on a number of factors including the angle of emission, the surface temperature of the surface, the micro-roughness of the surface (texture), the complex refractive index of the surface and the background temperature of the surrounding environment. The invention here primarily makes use of the fact that the polarization state of light emitted and reflected from the surfaces and objects is a function of angle of emission and different surface texture.

The emissivity of an object is determined from Kirchoff's radiation law. The most familiar form of Kirchoff's law is gives the emissivity of a surface ϵ in terms of the reflectance r , given by

$$\epsilon(\theta, \phi) = 1 - r(\theta) \tag{4}$$

where θ is the angle between the surface normal and the camera's line of sight. The more general equations for Kirchoff's law are given by

$$\epsilon_p(\theta) = 1 - r_p(\theta) \tag{5}$$

and

$$\epsilon_s(\theta) = 1 - r_s(\theta) \tag{6}$$

where the subscripts p and s denote the emissivity and reflectance of particular polarization states. The p-state indicates the plane of emission for light that is linearly polarized in a plane that contains the surface normal and the line of sight to the camera. For example, if the camera is looking down at a horizontal surface, the p-state of polarization would appear vertically polarized. The s-state of polarization is perpendicular to the p-state. Note that we have suppressed the temperature and wavelength dependence in equations 4-6.

Substituting equations (5) and (6) into equation (3) gives

$$\vec{s} = s_0 \begin{bmatrix} 1 \\ P(\theta)\cos(\phi) \\ P(\theta)\sin(\phi) \end{bmatrix} \tag{7}$$

where ϕ is the angle that the plane of incidence makes with the horizontal plane and

$$P(\theta) = \left(\frac{\epsilon_s(\theta) - \epsilon_p(\theta)}{\epsilon_s(\theta) + \epsilon_p(\theta)} \right) \tag{8}$$

Equation 8 can be written out more explicitly as

$$P(\theta) = \left(\frac{1 - r_s(\theta) - (1 - r_p(\theta))}{1 + r_s(\theta) + 1 + r_p(\theta)} \right) = \left(\frac{r_p(\theta) - r_s(\theta)}{2 + r_p(\theta) + r_s(\theta)} \right) \tag{9}$$

where r_p and r_s are given by the Fresnel equations for reflection

$$r_p = \sqrt{\frac{n^2 \cos(\theta) - \sqrt{n^2 - \sin^2(\theta)}}{n^2 \cos(\theta) + \sqrt{n^2 - \sin^2(\theta)}}} \tag{9a}$$

$$r_s = \sqrt{\frac{\cos(\theta) - \sqrt{n^2 - \sin^2(\theta)}}{\cos(\theta) + \sqrt{n^2 - \sin^2(\theta)}}} \tag{9b}$$

Note that $P(\theta)$ does not explicitly depend on the angle ϕ that the plane of incidence makes with the horizontal plane. The angle ϕ is critical to determine the orientation of plane of incidence and ultimately the azimuthal angle of the surface normal. The angle ϕ can be determined from the following angle,

$$\phi = \arctan\left(\frac{s_2}{s_1}\right) \tag{10}$$

The angle θ can be determined a number of ways. A method for determining θ and ϕ from a normalized Stokes image (Equation 3) are known in the art.

Also in step **1003**, a degree of linear polarization (DoLP) image is computed from the Stokes images. A DoLP image is useful for providing contrast for roadway surface and objects in the road, and can be calculated as follows:

$$DoLP = \sqrt{(s_1/s_o)^2 + (s_2/s_o)^2} \tag{11}$$

or

$$DoLP = \left(\frac{\epsilon_s(\theta) - \epsilon_p(\theta)}{\epsilon_s(\theta) + \epsilon_p(\theta)} \right) = \left(\frac{r_p(\theta) - r_s(\theta)}{2 + r_p(\theta) + r_s(\theta)} \right) \tag{12}$$

Note that DoLP is linear polarization. As one with skill in the art would know, in some situations polarization that is not linear (e.g., circular) may be desired. Thus in other embodiments, step **1004** may use polarization images derived from any combination of S_0 , S_1 , S_2 , or S_3 and is not limited to DoLP.

The DoLP image is one available image used to view polarization contrast in an image. Another alternative image to view polarization content is a "ColorFuse" image that is generated by mapping the radiance, DoLP, and orientation images to a color map. Persons with skill in the art makes the following mapping of polarization data to a hue-saturation-value representation for color:

$$\begin{aligned} S_0 &= \text{value} \\ DoLP &= \text{saturation} \\ \text{Orientation } \phi &= \text{hue} \end{aligned}$$

This representation enables display of all optical information (radiance and polarization) in a single image and provides a means to show both radiometric and polarization contrast enhancing understanding of the scene. In many cases where polarization contrast is strong, this representation provides scene context for the surfaces or objects that are polarized. Those experienced in the art can imagine other ways of doing this.

The ColorFuse is one embodiment of multidimensional representation that can be produced in step **1004**. Those knowledgeable in the art can conceive similar mappings. For one example, the DoLP information may be emphasized when radiance values are low.

As mentioned above, the polarization state emitted or reflected from the surface of objects or surfaces in the imaged scene depends on a number of factors including the angle of emission, the surface temperature of the surface, the micro-roughness or texture of the surface, and the complex refractive index of the surface. Generally speaking then, the contrast of surfaces and objects in the scene due to polarization are dependent on the geometry and the material or surface properties of the objects in the scene. While surface temperature contributes to polarization signature contrast, temperature differences of objects in the scene are not necessary in order for there to be polarization contrast. This is important because frequently many objects in an imaged scene can be at the same or very similar temperatures and hence show little contrast.

Because the underlying optical radiation depends on emission, no additional light sources, illumination, or ambi-

ent light is required for polarization imaging. This is a key point and differentiates this approach from all of the prior art. Further, the approach works equally well during the night time as it does during the day.

In step **1005**, contrast enhancing algorithms that are known in the art are applied to the multidimensional image from step **1004**. The multi-dimensional data exploits the polarization data to significantly enhance the information content in a scene. Non-restrictive examples include global mean, variance, and higher order moment analysis, Principal Component Analysis, or Linear Discriminate Analysis, computation of the statistics of the multidimensional data as a whole and then computation of local values based on a kernel convolved with the image as a whole and then normalized by global statistics of the scene.

In step **1006**, object detection algorithms that are known in the art are applied to the contrast enhanced data from step **1005**. Non-restrictive examples of object detection algorithms include setting manually or automatically a threshold value based on the image statistics, segmenting portions of the image based on the contrast enhancements, edge detection, and morphological properties.

In step **1007**, detected objects may then be annunciated to the user through visual or auditory means. Non-restrictive examples includes bells, buzzers or lights to draw the operator's attention to the display, or indications on the display such as distinctive colors or boxes in the region of the obstacle or surface. In addition or alternatively, in step **1007** enhanced contrast images may be displayed to the user (not shown).

In other embodiments, steps **1003**, **1004**, **1005**, and **1006** are used in combinations that omit one or more of the steps. In other embodiments, the polarization image data, or the multi-dimensional (ColorFuse) data, may be viewed by humans for object detection, and no algorithms are applied.

Algorithms that exploit a combination of image features extracted from a LWIR imaging polarimeter can be used to detect potential obstacles or roadway edges. In the case of train tracks, algorithms could be used to confirm continuity of the tracks automatically. Once potential noteworthy features are detected, they can be automatically highlighted for the operator, and a warning can be given through some annunciation mechanism (buzzer or light). Algorithms could also potentially be used to exploit the orientation information to help improve understanding of the image such as segmentation or shape recognition.

For the purposes of operating a vehicle, the enhanced contrast enables the mapping of features in the imaged scene that, through operator perception or automated detection and warning, improves the safety of the operator, or in the case of autonomously operated equipment such as agricultural equipment, provides autonomous obstacle avoidance to the steering or navigation systems. Specifically, improved detection and recognition of obstacles will allow the operator to maneuver the vehicle (or vessel) to avoid obstacles. Improved detection and perception of roadway edges will reduce chances of inadvertently leaving the roadway. This is especially true at night when the operator's vision is limited by darkness.

As discussed herein, the system and method of the present disclosure adds a polarimetric signature to the information that was previously attainable by an IR camera, i.e., temporal, special and IR signature. These four categories of information can be used simultaneously to classify/categorize objects detected. Further, the classification/categorization of the detected objects can influence evasive action to be taken by a vehicle. For example, a detected object in a

roadway may be classified as an obstacle that needs to be avoided, rather than a pothole the vehicle is capable of driving over. Further, multiple objects may be independently and simultaneously classified into separate groups or sub-groups based on their temporal, spatial, IR, and/or polarimetric signatures in accordance with given criteria.

FIG. **4a** depicts a visible image of a roadway **400** at night. FIG. **4b** is a thermal image of the same roadway **400** at night. Note that in FIG. **4b**, the roadway **400** and surrounding terrain have nearly the same temperature and hence there is little contrast between the roadway **400** and a shoulder **401** of the road in the thermal image. FIG. **4c** depicts a polarization image of the roadway **400** obtained with the system and method according to an exemplary embodiment of the present disclosure. The polarization image in **4c** shows strong contrast of the road **400** and the shoulder **401** is easily discernable. A white stripe **402** that parallels the roadway **400** on the left hand side is a sidewalk. The polarization image in **4c** was obtained with no external light source.

FIG. **5a** is a visible image of a roadway **500** during the daytime. FIG. **5b** is a thermal image of the roadway **500** of FIG. **5a**. The roadway **500** and other scene elements show confusing contrast in the thermal image of FIG. **5b**. FIG. **5c** is a polarization image of the roadway **500** of FIG. **5a** obtained with the system and method according to an exemplary embodiment of the present disclosure. The polarization image of FIG. **5c** shows strong contrast of only the roadway **500**. A sidewalk **501** that parallels the road on the left hand side and a driveway **502** on the right are easily discernable in the polarization image of FIG. **5c**. The sidewalk **501** and the driveway **502** are not easily perceptible in the thermal image of FIG. **5b**.

FIG. **6a** is visible image of a roadway **600** that has a median **601** and sidewalk **602**, shown at night. FIG. **6b** is a thermal image of the roadway **600** of FIG. **6a**, also at night. The roadway and surrounding terrain have similar temperatures and hence there is weak contrast between the roadway and the media of the road in the thermal image.

FIG. **6c** is a polarization image of the roadway **600** of FIG. **6a** obtained with the system and method according to an exemplary embodiment of the present disclosure. The polarization image of FIG. **6c** shows strong contrast of the roadway **600**. The sidewalk **602** that parallels the road on the right hand side and the median **601** are easily discernable in the polarization image of FIG. **6c**. The sidewalk **602** and the median **601** are not easily perceptible in the thermal image of FIG. **6b**.

FIG. **7a** is a visible image of a dirt road **700** depicting exemplary obstacles **701** on a road **700**. The obstacles **701** comprise wood planks in the image. FIG. **7b** is a thermal image of the road **700** of FIG. **7a**. In the image of FIG. **7b**, the obstacles **701** are easier to discern than in the visible image of FIG. **7a**. FIG. **7c** is a contrast enhanced thermal image of the road **700** of FIG. **7a**.

FIG. **7d** is a polarization image of the road **700** of FIG. **7a**. The obstacle **701** in this image is easily discerned, though the polarization image does not provide much context to the obstacle in relation to the road **700**. FIG. **7e** is a ColorFuse image of the roadway of FIG. **7d**. The ColorFuse image shows both thermal and polarimetric data in a single image, and provides the greatest contrast.

FIG. **8a** is a visible image of a dirt road **800** depicting exemplary obstacles **801** on a road **800** at night. The obstacles **801** comprise wet dirt and mud in the image. These are potential hazards which might immobilize some ground

vehicles. FIG. 8b is a thermal image of the road 800 of FIG. 8a. FIG. 8c is a contrast enhanced thermal image of the road 800 of FIG. 8a.

FIG. 8d is a polarization image of the road 800 of FIG. 8a. The obstacles 801 in this image are easily discerned, though the polarization image does not provide much context to the obstacles in relation to the road 800. FIG. 8e is a ColorFuse image of the roadway of FIG. 8d. The ColorFuse image shows both thermal and polarimetric data in a single image, and provides the greatest contrast. The ColorFuse image of FIG. 8e shows how the combination of thermal and polarization data products can be used to provide a good representation of road surfaces.

FIG. 9a (inset photo) is a visible image of train tracks 900 depicting exemplary segmentation of the rails in a railroad environment. FIG. 9b is a thermal image, in which identification of the tracks is difficult due to different temperatures of the objects in areas adjacent to the tracks. FIG. 9c is a polarimetric image of the train tracks 900 of FIG. 9a, and show good delineation of the tracks.

Similarly, for vessels navigating a body of water that need to avoid obstacles in the water, an LWIR polarimeter can be used to enhance contrast between obstacles that break the surface of the water and the water background. This can be particularly effective since objects floating in water tend to have the same temperature as the water they're floating in and can hence be difficult to detect through the radiometric (thermal) image.

FIGS. 10a, 10c, and 10d are Stokes vector images S_0 , S_1 and S_2 , respectively, of a maritime scene showing fishermen in a boat. FIG. 10e is a DoLP image of the same scene. FIG. 10b is a ColorFuse image of the scene. The ColorFuse image shows improvement in contrast for obstacle avoidance for vessels or advantage for search and rescue.

What is claimed is:

1. A method of detecting objects along a path from a moving vehicle, the method comprising:
 - recording raw image data of an area using a polarimeter to obtain polarized images of the area;
 - calculating Stokes parameters S_0 , S_1 , and S_2 from the polarized images to create Stokes images by weighted subtraction of the polarized images;
 - computing DoLP images and orientation images from the Stokes images;
 - creating multi-dimensional imagery using one or more of: the polarized images, the Stokes parameters, the DoLP images and the orientation images;
 - applying contrast enhancement algorithms to the multi-dimensional imagery to form enhanced object images;
 - automatically recognizing the objects from the enhanced object images.
2. The method of claim 1, further comprising generating a map of objects detected.
3. The method of claim 1, further comprising displaying the enhanced object images to a user.
4. The method of claim 1, further comprising annunciating detected objects to a user.

5. The method of claim 1, further comprising automatically taking evasive action to avoid detected objects.

6. The method of claim 1, further comprising performing corrections on the polarized images by correcting the polarized images for non-uniformity.

7. The method of claim 6, wherein the step of performing corrections on the polarized images further comprises performing optical distortion and registration corrections.

8. The method of claim 1, wherein the path comprises a roadway and the method comprises identifying objects useful for safe navigation of the vehicle on the roadway.

9. The method of claim 1, wherein the path comprises a railway and the method comprises identifying objects useful for safe navigation of a vehicle on the railway.

10. The method of claim 1, wherein the path comprises a waterway, and the method comprises identifying objects on the waterway.

11. The method of claim 1, wherein the path comprises an air route and the method comprises identifying objects from an aircraft.

12. A method for mapping a roadway comprising:
 - recording raw image data of the roadway from a moving vehicle with a polarimeter to obtain polarized images of the roadway;
 - performing corrections on the polarized images to form corrected images;
 - computing IR and polarization data products from the corrected images;
 - converting the IR and polarization data products to a multi-dimensional data set to form multi-dimensional imagery;
 - applying contrast enhancement algorithms to multi-dimensional imagery to form enhanced object images;
 - recording in memory the location of objects detected in the roadway;
 - classifying detected objects based upon one or more of: their temporal, spatial, IR, or polarimetric signatures, wherein multiple objects may be independently classified into separate groups or sub-groups based upon one or more of: their temporal, spatial, IR, or polarimetric signatures; and
 - using the classification of objects to determine and initiate appropriate evasive action to avoid detected objects.

13. The method of claim 12, wherein the step of recording raw image data of the roadway is not dependent upon the brightness of available light.

14. The method of claim 12, where the step of recording raw image data of the roadway does not require a light source.

15. The method of claim 12, further comprising automatically taking evasive action to avoid objects in the roadway.

16. The method of claim 12, further comprising identifying edges of the roadway.

17. The method of claim 12, further comprising identifying water or mud in the roadway.

* * * * *